

CONVEYOR BELTS SCRAPERS

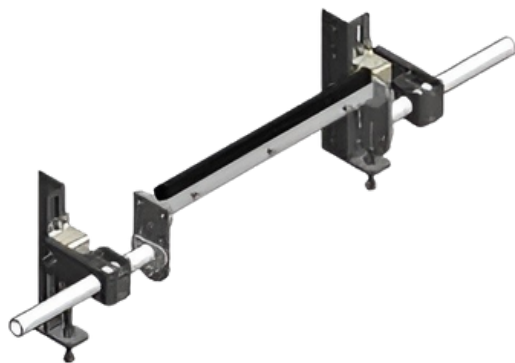

LOWER BELT SCAPER

- Robust steel frame with cathododesis paint for durability, stainless steel;
- Mono-polyurethane blade with tungsten inserts, a painted steel blade with tungsten inserts, or a corrosion-resistant stainless steel blade;
- Save space with a removable, interchangeable design;
- Minor modification for widths 1200 and 1400, while ensuring reliability.



FRONT BELT SCAPER

- Robust steel with cathododesis paint or durable stainless steel for extended longevity;
- Polyurethane scraper blade ensures no product lodges in belt interstices, preventing any compromise in cleaning effectiveness;
- Resilient elastic bearings.



DOUBLE SCAPER

- Robust steel frame with cathododesis paint, resilient stainless steel frame;
- Polyurethane (with or without tungsten inserts), painted steel with stainless steel or tungsten inserts;
- Resilient elastic bearings.