

FLAP DIVERTER



45° - 60° SYMMETRICAL 2 WAY



- Shaft with ball bearing for smooth operation;
- Galvanized steel lid for durability and easy maintenance access;
- High-resistance dynamic sealing for effective dust protection;
- Durable steel construction, ATEX Directive Zone 21 compliant;
- Ideal for bulk material processing and grain transportation;
- Accommodates particle sizes down to 0.5 mm;
- 400×400 mm window for ample passage;
- 45° tilt angle for efficient material redirection;
- 5 mm valve body thickness for added strength.

45° - 60° ASYMMETRICAL 2 WAY



- Smooth operation with ball bearing shaft;
- Durable galvanized steel lid for easy maintenance;
- High-resistance dynamic sealing for effective dust protection;
- Built to last with durable steel construction, ATEX Directive Zone 21 compliant;
- Ideal for bulk material processing, especially grain transportation;
- Accommodates particle sizes down to 0.5 mm;
- Compact design with a 200×200 mm window;
- 45° tilt angle for efficient material redirection;
- Sturdy 3 mm valve body thickness for reliability.

FLAT 2 WAY DIVERTER



- Smooth operation with ball bearing shaft;
- Durable galvanized steel lid;
- Easy-to-dismantle flap for maintenance;
- High-resistance dynamic sealing for dust protection;
- Constructed from durable steel, ATEX Zone 21 compliant;
- Ideal for bulk material processing, especially grains;
- Accommodates particle sizes down to 0.5 mm;
- 300×300 mm window for clear visibility;
- 45° tilt angle for efficient redirection;
- Sturdy 4 mm valve body thickness.

45° - 60° ASYMMETRICAL 3 WAY DIVERTER

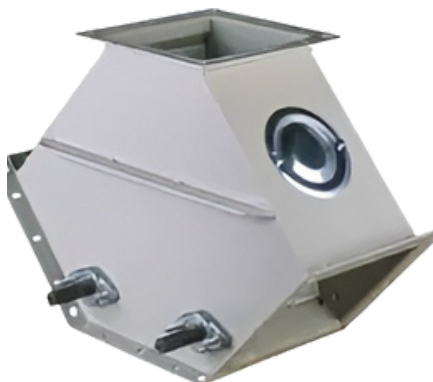

- Smooth operation with ball bearing shaft;
- Durable galvanized steel construction, ATEX Zone 21 compliant;
- Easy-to-dismantle flap with high-resistance dynamic gasket;
- Effective dust protection with dynamic sealing;
- Suitable for bulk material processing, especially grains;
- Handles particle sizes from 0.5 mm;
- Large 450×450 mm window for clear visibility;
- 45° tilt angle for efficient redirection;
- Robust 5 mm valve body thickness.

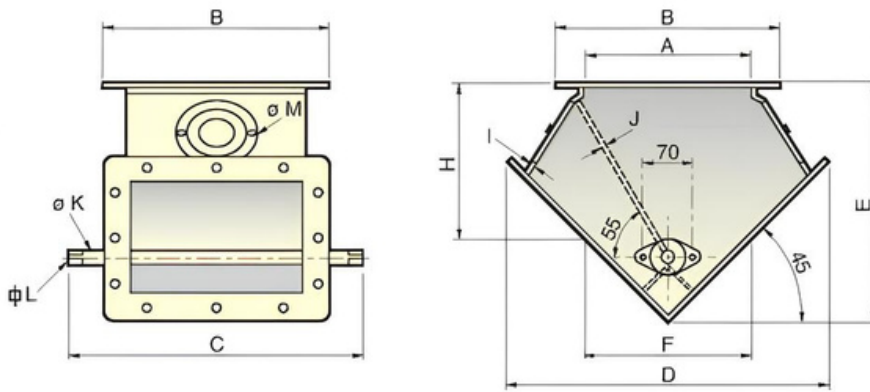

45° - 60° SYMMETRICAL 2 WAY

Featuring a standard one-coat paint finish in RAL 7032, an axle installed on ball bearings, a galvanized steel inspection cover, and a dismantlable flap with a permanent pressure dynamic gasket, our product ensures robust construction and effective dustproofness.

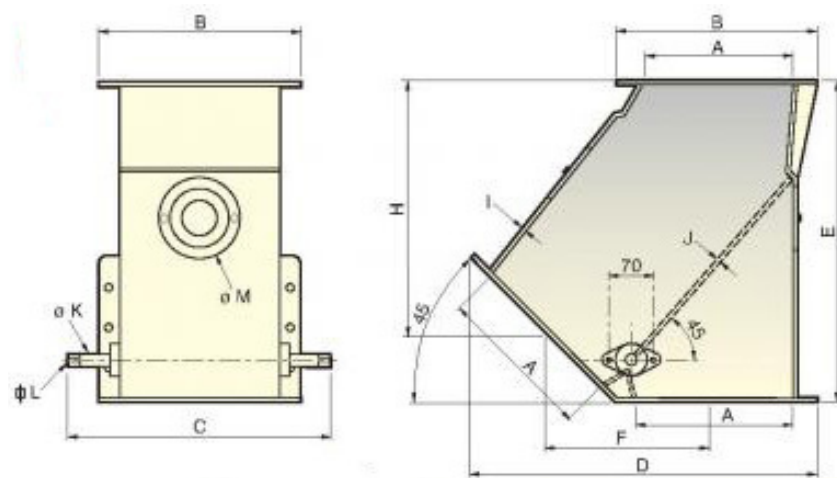

45° - 60° ASYMMETRICAL 2 WAY

Our product is characterized by a standard one-coat paint finish in RAL 7032, an axle installed on ball bearings, a galvanized steel inspection cover, a dismantlable flap with permanent pressure, and efficient dustproofing ensured by a high-resistance dynamic gasket.

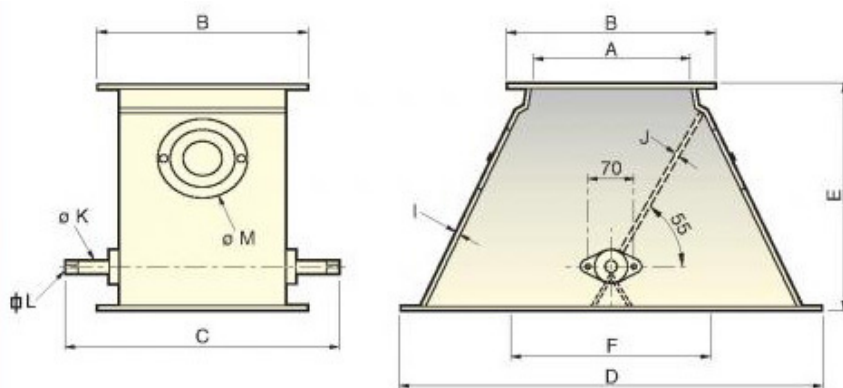

FLAT 2 WAY DIVERTER

Our product boasts a one-coat paint finish in RAL 7032, an axle installed on ball bearings, a galvanized steel inspection cover, a dismantlable flap with permanent pressure, and effective dustproofing through a high-resistance dynamic gasket.

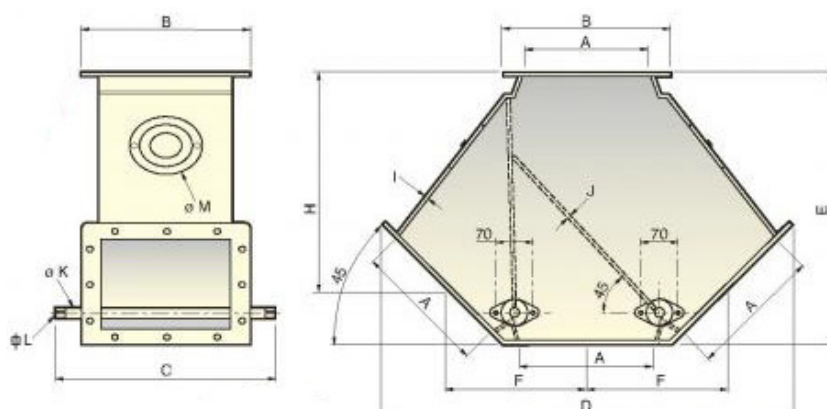

45° - 60° SYMMETRICAL THREE WAYS DIVERTER

With a standard one-coat paint finish in RAL 7032, an axle installed on ball bearings, a galvanized steel inspection cover, and a dismantlable flap with permanent pressure, our product ensures reliable dustproofing through a high-resistance dynamic gasket.