

## FORGED LINK STANDARD SERIES

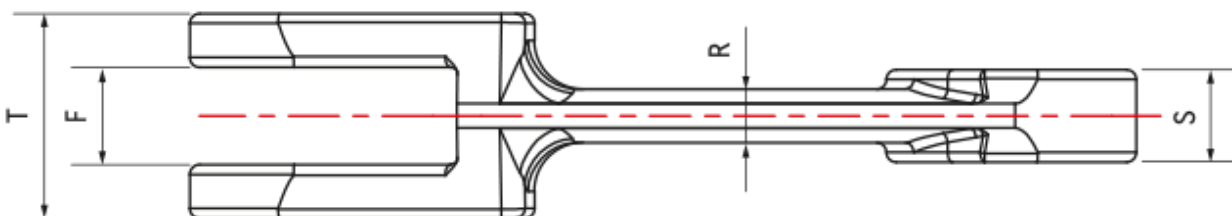

### FORGED LINK STANDARD SERIES

This series stands out as the forefront product in the market. Forged fork link chains have emerged as exceptionally reliable conveying mediums, showcasing a unique blend of versatility, strength, and abrasion resistance. Originally of European origin, these chains have now gained global recognition.

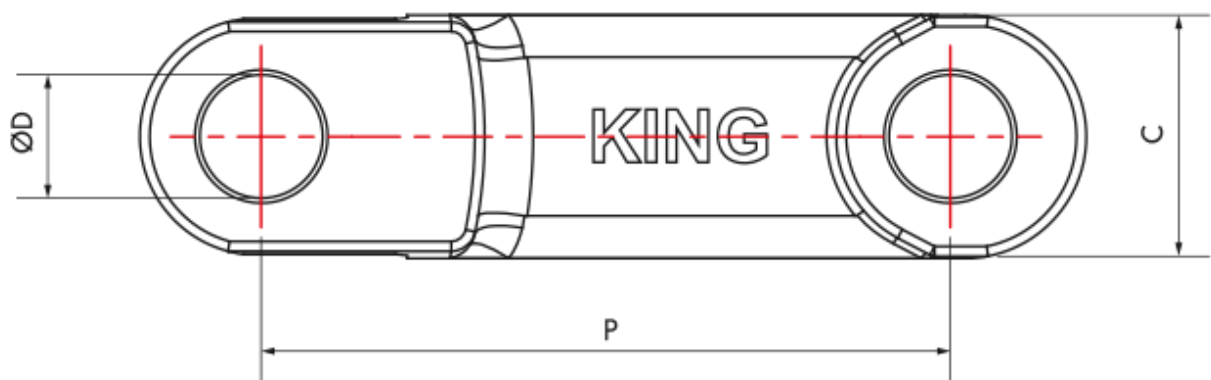

FORGED LINK STANDARD SERIES

Chain Number	P	T	C	S	F	R	D	TN*	CN*	CD*	Weight
JKF 10160	101.6	24	36	9	10	6	14	110	120	210	3.50
JKF 10160R	101.6	30	36	13	14	9	14	180	195	330	4.80
JKF 12514	125	30	36	13	14	10	16	163	175	290	4.40
JKF 14214	142	32	41	14	15	9	18	180	195	330	4.90
JKF 14218	142	42	50	19	20	12	25	290	320	550	9.40
JKF 14222	142	54	50	25	27	16	25	370	400	655	12.20
JKF 14226	142	62	50	28	30	16	25	440	470	790	13.60
JKF 16018	160	46	46	22	24	15	22	320	342	560	9.30
JKF 16025	160	50	53	23	25	13	25	370	400	655	10.80
JKF 20025	200	60	50	25	27	18	25	380	410	679	11.30
JKF 20028	200	66	60	30	32	20	30	500	540	900	16.70
JKF 21640	216	64	72	26	28	20	35	585	630	1035	20.10
JKF 22040	220	64	72	26	28	20	35	585	630	1035	20.30
JKF 22050	220	58	75	28	30	25	32	710	760	1260	19.10
JKF 22060	220	71	75	31	33	21	35	735	790	1300	22.90
JKF 25040	250	70	75	32	34	18	32	735	860	1430	18.80
JKF 26035	260	65	75	31	33	20	32	840	900	1480	19.80
JKF 26040	260	70	75	31	33	20	32	840	900	1480	21.00
JKF 26045	260	78	75	35	37	20	32	930	1000	1650	21.80