

FORGED LINK DOUBLE SERIES

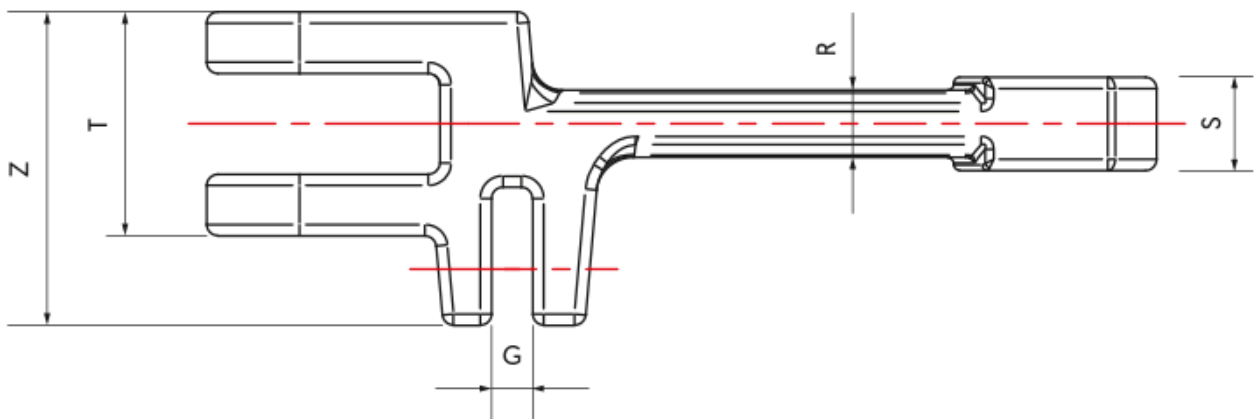

FORGED LINK DOUBLE SERIES

For the dual strand, we offer a variety of links adhering to the standard format but featuring a forged "double clevis" for the attachment of a scraper. The flight blade can be secured using either a U-bolt or conventional fasteners. This chain incorporates built-in clearance between strands, mitigating potential issues associated with mismatch.

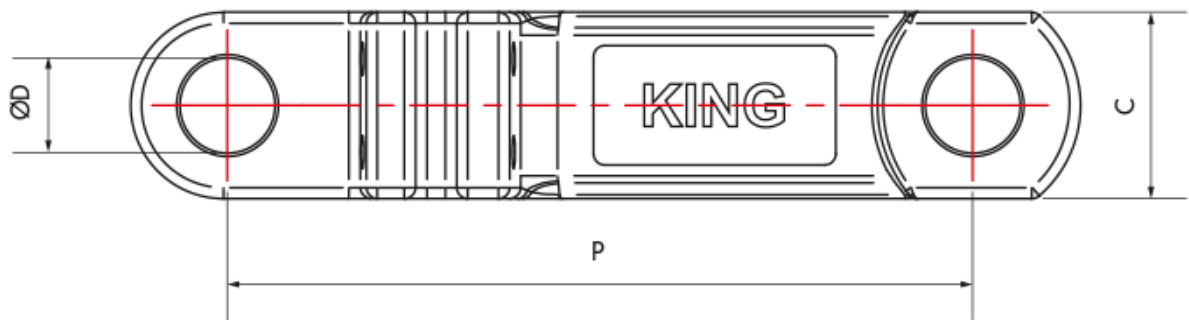

FORGED LINK DOUBLE SERIES

Chain Number	P	T	C	S	Z	G	D	TN*	CN*	CD*	Weight
JKF 142182	142	42	50	19	70	13	25	290	320	550	11.80
JKF 142262	142	62	50	28	87	13	25	440	470	790	16.70
JKF 160252	160	50	53	23	82	13	25	370	400	655	13.60
JKF 175402	175	72	60	30	95	16	30	540	580	955	20.30
JKF 200252	200	60	50	25	81	12	25	380	410	670	13.00
JKF 200402	200	70	60	30	95	13	30	540	580	955	19.30
JKF 250252	250	60	50	25	81	12	25	380	410	670	12.00
JKF 250402	250	70	60	30	95	13	30	540	580	955	17.70
JKF 250602	250	100	70	45	140	21	35	975	1050	1720	35.20