

DURABELT™

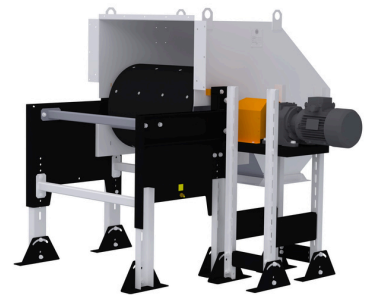

- Our conveyor rollers meet ISO 1537:2006 standards or can be customized;
- Constructed from electro-welded pipes (63mm to 159mm);
- Adaptable to diverse conveyor systems;
- Quality labyrinth seals enhance bearing longevity;
- Featuring a 750mm working surface for optimized material handling and increased productivity.

- Sturdy frame: cataphoresis paint or stainless steel;
- Blade options: mono-polyurethane with tungsten, painted steel with tungsten, or corrosion-resistant stainless steel;
- Space-saving design: interchangeable components;
- Reliable for 1200 and 1400 widths.
- Prevents product lodgement: polyurethane scraper blade;
- Long-term reliability: resilient elastic bearings.

- Drum with a detachable lining for quick replacement;
- Modular design for various drive implementations;
- Lining of the discharge housing.

- Explosion-proof inlet and outlet devices;
- High durability: Over 30,000 hours of operation;
- Abrasion-resistant construction;
- Optional weather shelter;
- Lining options: HDPE, Polyurethane, HARDOX 450;
- Enhanced support at loading points;
- Dual-Sided Safety Sensors: Belt Run-off, Belt Speed, Emergency Switch;
- Scraper cleaning for belt maintenance;
- Reversible functionality;
- Automatic (or manual) dumping cart for efficient loading;
- Antistatic, oil-resistant, and frost-resistant conveyor belt;
- Additional Safety Sensors: Inspection Hatch Openings, Safety Guard Removal, Back Pressure;
- Seamless integration with aspiration systems;
- ATEX22 and ATEX21 compliant versions for hazardous environments;
- Additional swivel self-centering roller supports for stability.



- Guaranteed productivity - 100, 150, 200, 250, 300, 350, 450, 500, 1000, 1500 t/h;
- Product displacement without losses;
- 100% preservation of product quality;
- Dual-Sided Safety Sensors: Belt Run-off, Belt Speed, Cable Emergency Switch;
- Scaper cleaning for drive station belt maintenance;
- Reversible functionality for versatile operations;
- Automatic (or manual) dumping cart for efficient loading into floor storage warehouses;
- Conveyor belt features antistatic, oil-resistant, and frost-resistant properties;
- Additional Safety Sensors: Monitoring Inspection Hatch Openings, Safety Guard Removal, and Back Pressure;
- Seamless integration with aspiration systems;
- ATEX22 and ATEX21 compliant version available for hazardous environments;
- Additional swivel self-centering roller supports for enhanced stability.

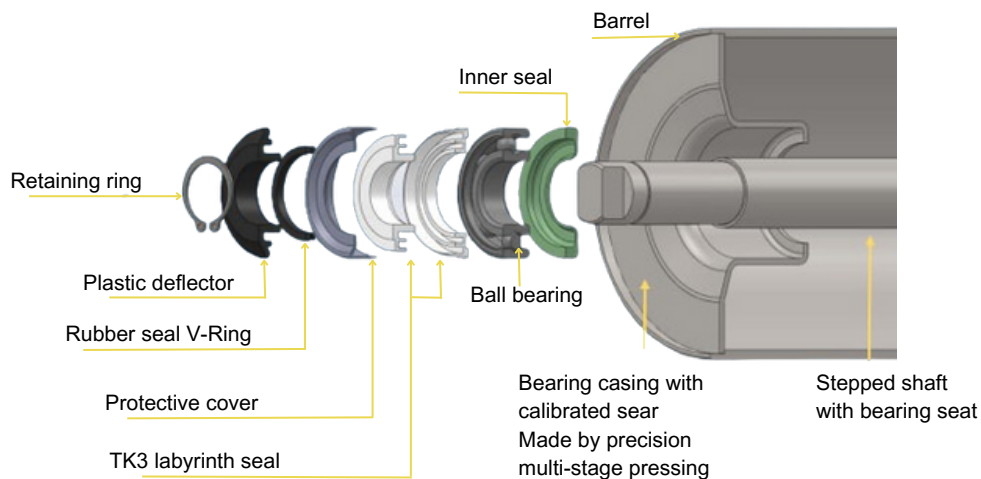

M-JET®



- Pulse range: 6-6000 pulses/min, max speed: 500 rpm;
- Preset under speed settings: -33/-20/-11/-6%;
- Intuitive setup with M12 bolt and anti-rotation strap;
- Compliance with standards: 2014/34/UE, EN/IEC 60079-0, EN/IEC 60079-31;
- IP6X-IEC 60529 rating for robust, dustproof, waterproof casing;
- Remote management capability, flexible power options;
- Comprehensive sensor array for monitoring;
- Suitable for ATEX zone European regulation 2014/34UE.



The continuous belt conveyor smoothly transports bulk cargo with safety handling and minimal damage. It operates horizontally, at an inclined position ranging from -10° to +30°, or in a horizontal-inclined combination.

Conveyors with low productivity

Capacity, t/h	A,mm	B,mm	C,mm	D,mm	E,mm	β°	m*, kg/m
50	950	400	760	750	160	30	60
100	950	500	880	800	200	30	75
150	980	600	920	860	240	35	85
200	990	650	960	900	250	45	105

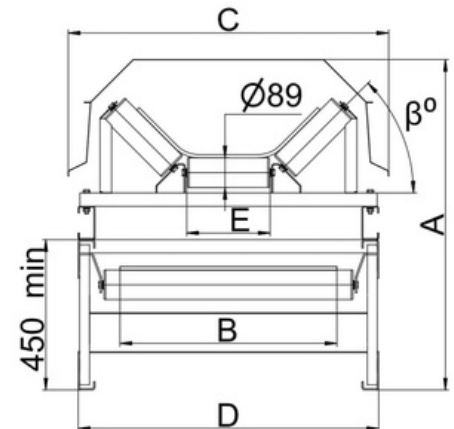

High-performance conveyors

Capacity, t/h	A,mm	B,mm	C,mm	D,mm	E,mm	β°	m*, kg/m
300	1480	800	1210	1150	315	45	145
500	1600	1000	1410	1350	380	45	175
1000	1775	1200	1660	1600	465	45	240
1500	1825	1400	1860	1800	530	45	290

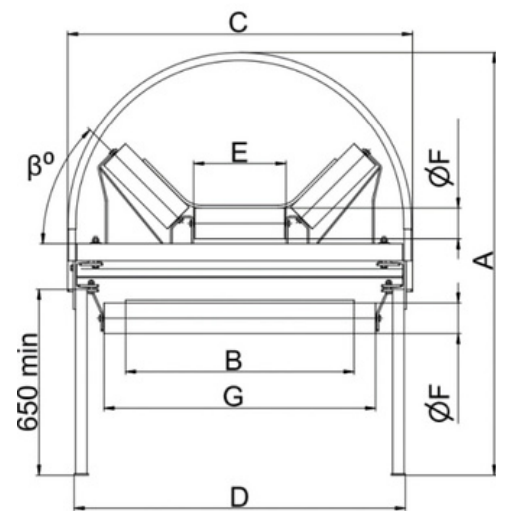

Equipment supply/provision

Equipment category	Lite	Standard	Professional
Drive	NRW	NORD	SEW Eurodrive
Bearings	CX	SNR	SKF
Rollers	SKIF	SKIF	SKIF/Sandvik
Belt EP400(500)/3	Artego	Artego	SAVA / SIG
Properties of the belt	General purpose	Oil-resistant, antistatic	Oil-resistant, antistatic, frost-resistant

The conveyor efficiently guides material into a bulk chute and is designed for reliable performance. It comprises a drive unit, tensioning unit, and conveyor sections with supporting rollers.

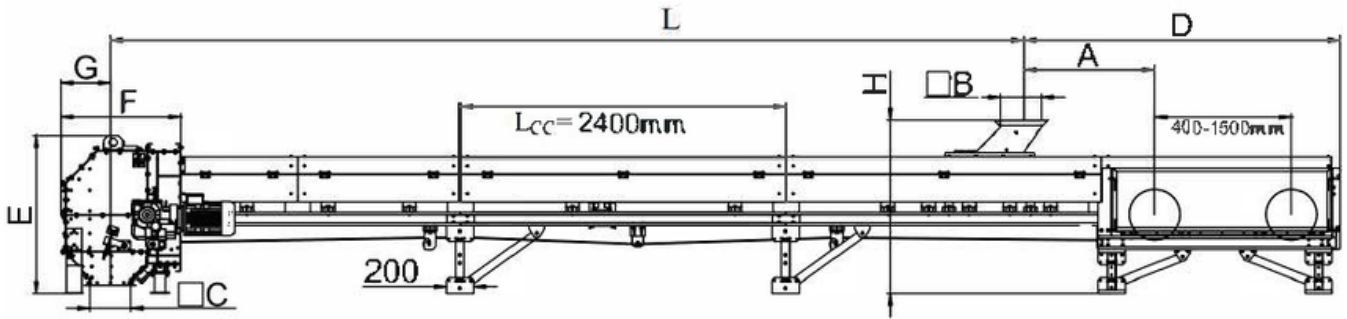

Specifications of conveyors with low productivity

Model	A,mm	B,mm	C,mm	D,mm	E,mm	F,mm	G,mm	H,mm
50	800	250	250	1350/2 450*	1160	885	365	1270
100	1000	300	300	1550/2 650*	1160	885	365	1270
150	1200	400	400	1750/2 850*	1190	985	415	1300
200	1300	400	400	1950/3 050*	1200	1000	415	1350

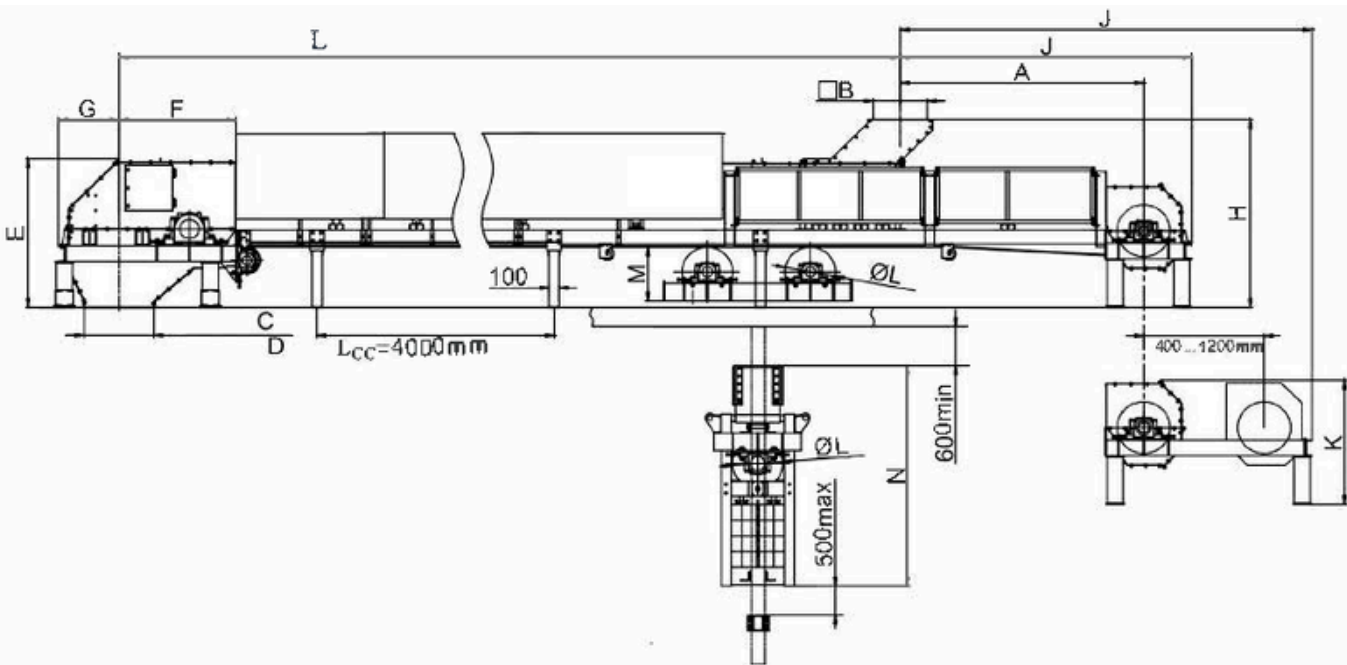

Specifications of high-performance conveyors

Model	A,mm	B,mm	C,mm	D,mm	E,mm	F,mm	G,mm	H,mm	J,mm	K,mm	L,mm	M,mm	N,mm
300	2150	450	600	600	1110	700	445	1320	2600/ 3800*	920	425	500	1800
500	2200	500	600	600	1350	1150	650	1650	2700/ 4100*	1100	500	550	2000
1000	2400	600	700	800	1520	1160	700	1920	2900/ 4100*	1265	500	620	2200
1500	2550	700	700	800	1700	1220	700	2000	3100/ 4300*	1300	630	715	2500