

# BRITSKÉ ŠTANDARDNÉ DUTÉ KOLÍKOVÉ REŤAZE

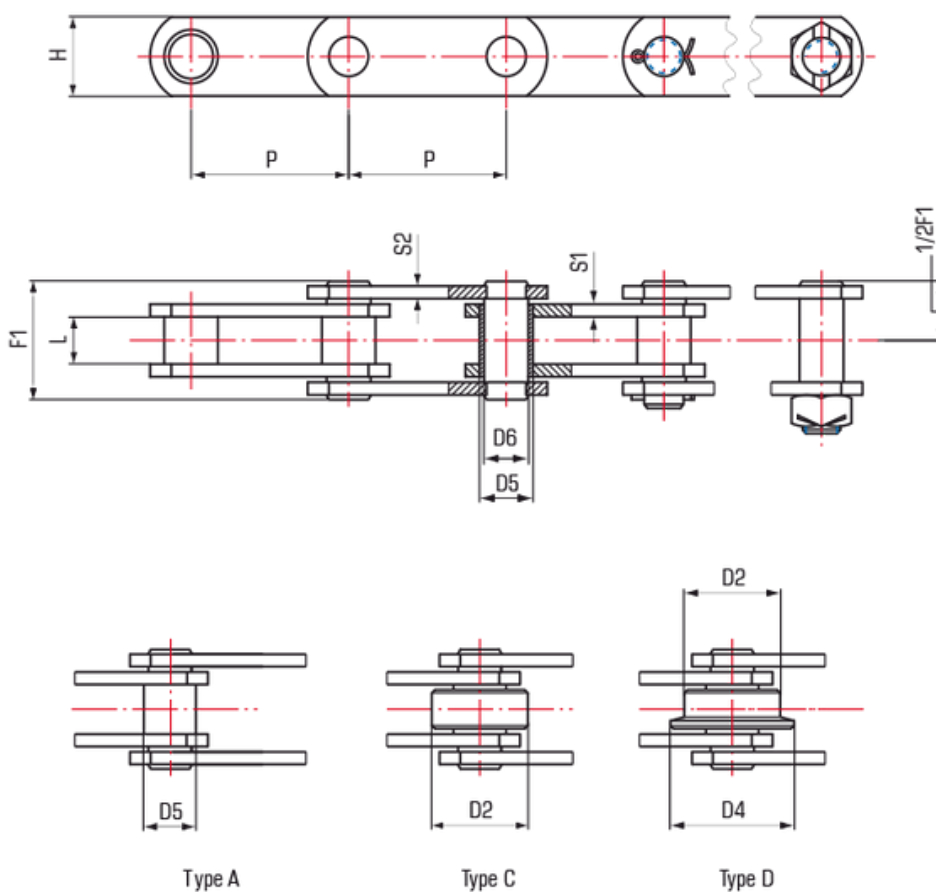

## BRITSKÉ ŠTANDARDNÉ DUTÉ KOLÍKOVÉ REŤAZE

Britská štandardná séria JOHN KING s dutými časmi poskytuje možnosť upevnenia príloh na vonkajšie platne cez dutý ložiskový čas. Príloha sa môže utiahnuť tesne proti dutému čapu alebo nechať vo voľnom režime. Typickým príkladom je, keď je reťaz prevádzkovaná v dvojitém vlákne s alebo bez prikrývky mriežky. Reťaz tohto konštrukčného typu stráca priemerne 20 % svojej konečnej pevnosti.



BRITSKÉ ŠTANDARDNÉ REŤAZE S DUTÝM ČAPOM BS 4116 (SÉRIA HP)

Refazové číslo	P	Prelomenie Zafaženie		Priemerná hmotnosť	Valčeky			Puzdrá Vonkajšie Priemer	Celkové	Medzi bočnými panelmi	Postranné panely			Priemer kolíkov	Dutý Kolík Priemer
					D2	D4	Hrúbka príruby				Hrúbka		Výška		
											D5	F1			
mm	kN	kN*	kg/m	mm											
HP27/0508/P	50.8	27	54	3.50	31.75	40	5	17	37	15	4	4	25	14	10.2
HP27/0635/P	63.5	27	54	3.13	31.75	40	5	17	37	15	4	4	25	14	10.2
HP27/0762/P	76.2	27	54	2.88	31.75	40	5	17	37	15	4	4	25	14	10.2
HP27/0889/P	88.9	27	54	2.71	31.75	40	5	17	37	15	4	4	25	14	10.2
HP27/1016/P	101.6	27	54	2.58	31.75	40	5	17	37	15	4	4	25	14	10.2
HP27/1270/P	127.0	27	54	2.39	31.75	40	5	17	37	15	4	4	25	14	10.2
HP27/1524/P	152.4	27	54	2.27	31.75	40	5	17	37	15	4	4	25	14	10.2
HP55/0762/P	76.2	55	110	6.93	47.5	60	6	23	45	19	5	4	40	19	13.2
HP55/0889/P	88.9	55	110	6.35	47.5	60	6	23	45	19	5	4	40	19	13.2
HP55/1016/P	101.6	55	110	5.91	47.5	60	6	23	45	19	5	4	40	19	13.2
HP55/1270/P	127.0	55	110	5.30	47.5	60	6	23	45	19	5	4	40	19	13.2
HP55/1524/P	152.4	55	110	4.89	47.5	60	6	23	45	19	5	4	40	19	13.2
HP55/1778/P	177.8	55	110	4.60	47.5	60	6	23	45	19	5	4	40	19	13.2
HP55/2032/P	203.2	55	110	4.39	47.5	60	6	23	45	19	5	4	40	19	13.2
HP110/1016/P	101.6	110	200	12.14	66.7	82	9	33	58	26	7	5	50	26.9	20.2
HP110/1270/P	127.0	110	200	11.21	66.7	82	9	33	58	26	7	5	50	26.9	20.2
HP110/1524/P	152.4	110	200	10.91	66.7	82	9	33	58	26	7	5	50	26.9	20.2
HP110/1778/P	177.8	110	200	9.46	66.7	82	9	33	58	26	7	5	50	26.9	20.2
HP110/2032/P	203.2	110	200	8.92	66.7	82	9	33	58	26	7	5	50	26.9	20.2
HP110/2286/P	228.6	110	200	8.50	66.7	82	9	33	58	26	7	5	50	26.9	20.2
HP110/2540/P	254.0	110	200	8.10	66.7	82	9	33	58	26	7	5	50	26.9	20.2
HP160/1524/P	152.4	160	320	22.18	88.9	114	10.5	38	78	38	8	8	60	32	22.5
HP160/1778/P	177.8	160	320	20.18	88.9	114	10.5	38	78	38	8	8	60	32	22.5
HP160/2032/P	203.2	160	320	18.68	88.9	114	10.5	38	78	38	8	8	60	32	22.5
HP160/2540/P	254.0	160	320	16.60	88.9	114	10.5	38	78	38	8	8	60	32	22.5
HP160/3048/P	304.8	160	320	15.19	88.9	114	10.5	38	78	38	8	8	60	32	22.5